

Dual Level Controller Manual



The DEETER Group[®]

Contents

	Page
Packing list	3
Description	3
Installation Guide	4
Wiring Instructions	5
DLC2 Auxiliary Relay	6
Wall Mounting	7
Junction Box Wiring	7
Application Notes	8
Safety Warnings	13

The DEETER Group®

Packing List

Open the outer carton and check all parts listed below are enclosed and undamaged. If any parts are missing or damaged please contact the Deeter Group.

- 12Volt power supply unit with European, UK and US style mains plug adaptors.
- Controller box with lid, lid screws and sealing gasket fitted.
- Wall-mounting kit containing four long screws, four short screws, four mounting crosses and four Rawlplugs.
- Junction Box
- This User Manual.

Description

Dual Level Controllers (DLC-I and DCL-II) provide safe control of mains voltages from two low-voltage float-switches with isolation provided by a relay.

The relay has a latching action and is typically used to drive a pump which will come on when the liquid level reaches the bottom float-switch and stay on until the level reaches the top switch. Alternatively, the relay can drive a valve or pump that will empty a tank, coming on when the top level is reached and staying on until the bottom level is detected.

The DCL-II can accept a third float-switch to control an auxiliary relay, typically used for driving an overflow or a low-level alarm. The auxiliary relay is directly controlled by the float-switch without any latching action.

- The relay contacts are rated at 8 amps and 240VAC. Please ensure your pump or valve cannot exceed these ratings.
- The float-switches (not included) must be capable of switching 100mA at 12VDC – contact the Deeter Group for suitable switches.

Installation Guide

The following wiring diagrams show the two most popular configurations for the DLC.

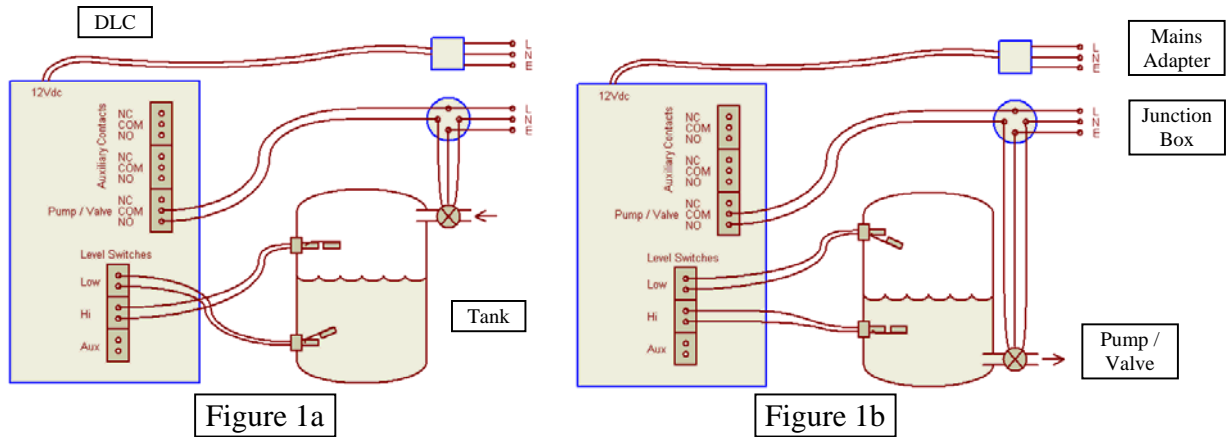

In Figure 1a the pump is used to fill the tank. The top float-switch goes to the terminals labelled “Hi” and the bottom switch to the terminals labelled “Low”. Note that the switches are open when the float rises (open when full).

In Figure 1b the pump is used to empty the tank. The float-switches go to the opposite terminals and they open when the float falls (open when empty).

Step-By-Step Installation Guide

The following table shows the correct combination of switch orientation and tank position for a given pump (or valve) function and choice of relay contacts.

Connector Labels	Pump or Valve Function		Switch Tank Position		Float-Switch Orientation
	‘NO’	‘NC’	‘Hi’	‘Low’	
Row 1	Fill	Empty	Top Switch	Bottom Switch	Open when full / closed when empty
Row 2	Empty	Fill	Bottom Switch	Top Switch	Open when empty / closed when full

- Step 1 – Choose a Fail-Safe Relay Contact

When power is removed from the DLC the relay normally-closed (NC) contact is connected to the common (COM) contact. For **fail-safe** operation, use the normally-open (NO) contact to drive equipment that must be **off**, and the NC contacts to drive equipment that must remain **on** during a DLC power failure.

- Step 2 – Select Table Row

From the Pump or Valve Function column of the table, select the row that represents your installation. For example, if the system is required to fill the tank and for fail-safe operation the ‘NO’ contacts are required, the switch positions and orientation are given by Row 1.

- Step 3 – Assign Switch Inputs to Tank Positions

The float-switch terminal pairs are labelled 'Hi' and 'Low' and for the majority of installations the top switch will go to 'Hi' and the bottom switch to 'Low'. However, if Step 2 selects Row 2 of the table, the terminal pairs must be swapped.

- Step 4 – Choose Switch Orientation

Figures 1a and 1b show the float-switches mounted in different ways. In Figure 1a the switches close when empty and open when full (i.e. when the liquid raises the float). Figure 1b shows the alternative arrangement – open when empty/closed when full. The correct orientation for your installation will be determined in Step 2 and shown in the last column of the table.

Wiring Instructions

Consult a qualified electrician if you're unsure how to install this device.

Note: When power is removed from the DLC the relay 'COM' contact is connected to the 'NC' contact. For fail-safe operation, use the 'NO' contact to drive equipment that must be off, and the 'NC' contacts to drive equipment that must remain on during a power failure.



- **WARNING:** turn off mains power before attempting to wire to this device!
- Connect the float-switch wires to the screw terminal pairs marked "Hi" and "Low". (See the table in the Installation Guide section to check which float-switch should go to which input pair).
- Strip back approximately 35mm of the outer sheath of 2-core mains cable from the pump and feed it through the central cable gland into the box.
- Connect the mains input LIVE wire to the terminal marked 'COM' and connect the switched LIVE to either the 'NC' or 'NO' terminal depending on the pump function (see Installation Guide section).

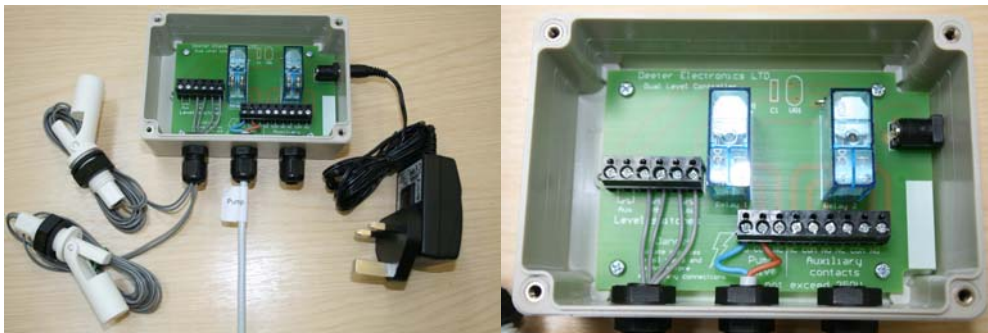

Figure 2

- Fit the Dual Level Controller lid.
- Connect the 12VDC power supply plug to the Dual Level Controller power socket.

DLC-II Auxiliary Relay

The DLC-II has an additional float-switch input to activate an auxiliary relay. This is typically used to provide an overflow or low level alarm, but has many possible uses.

The auxiliary relay is directly controlled by the float-switch without any latching action – the 'COM' connects to the 'NC' contact when the switch is open and to the 'NO' contact when it is closed.

The auxiliary relay is a double-pole type, providing two pairs of contacts. This allows a flexible range of options, for example, powering a normally-on AND a normally-off device, or switching currents greater than 8 amps by combining contact pairs.



- **WARNING:** turn off mains power before attempting to wire to this device!
- Connect the two wires from the auxiliary float-switch, through the left hand cable gland and connect to the screw terminals labelled 'Aux'.
- Feed the wires from the alarm (or other device) through the right hand cable gland and connect one wire to the terminal marked 'COM' in the 'Auxiliary Contacts' section, and the other wire into an adjacent 'NC' or 'NO' terminal.
- Connect the second set of auxiliary contacts if required.

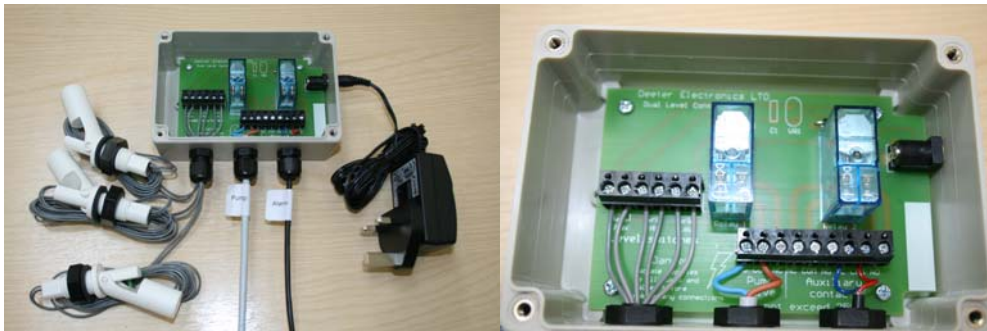

Figure 3

- Fit the Dual level controller lid.
- Connect the 12VDC power supply plug to the Dual Level Controller power socket.

Wall Mounting

The DLC can be mounted on a wall using the mounting kit provided:

- Fit all four mounting crosses to the base of the control box using the short screws (see picture below). The mounting cross bosses fit into the box.
- Choose a suitable wall location where all cables will reach and mark the position of the holes on the wall.
- Drill the wall using a 5mm masonry bit.
- Push the wall plugs into the holes and attach the control box using the four long screws.

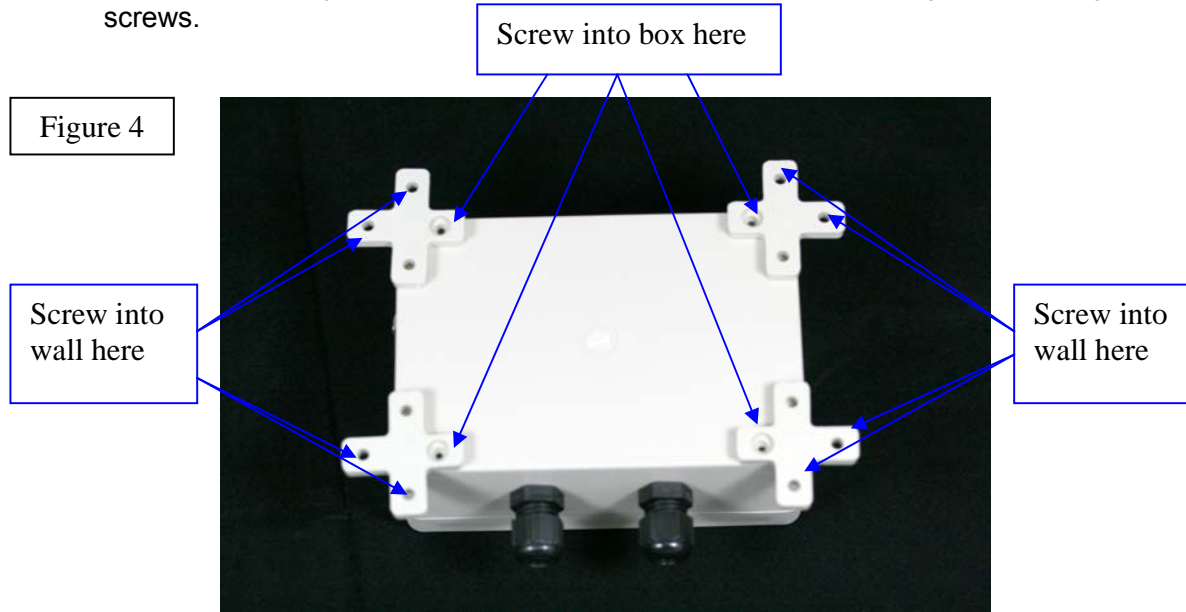

Junction Box Wiring

A junction box is provided to intercept the mains wiring to the pump. Unscrew the lid of the junction box and wire it as illustrated below.

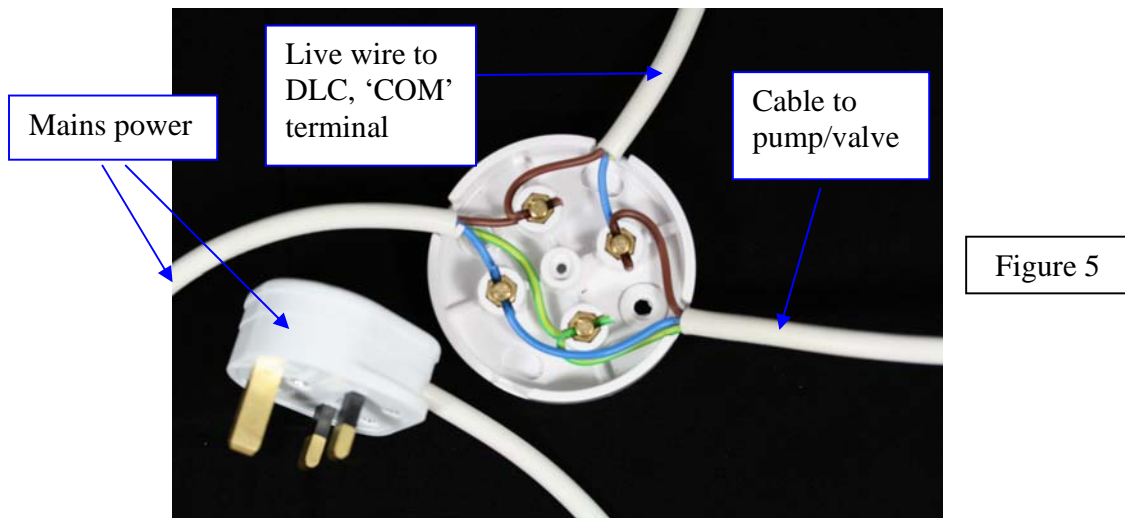

The DEETER Group[®]

Application Notes

KEY

Earth  Live  Neutral 

This Diagram shows how a 'Dual Level Controller 1' can manage the liquid level by pumping out a constantly filling tank.

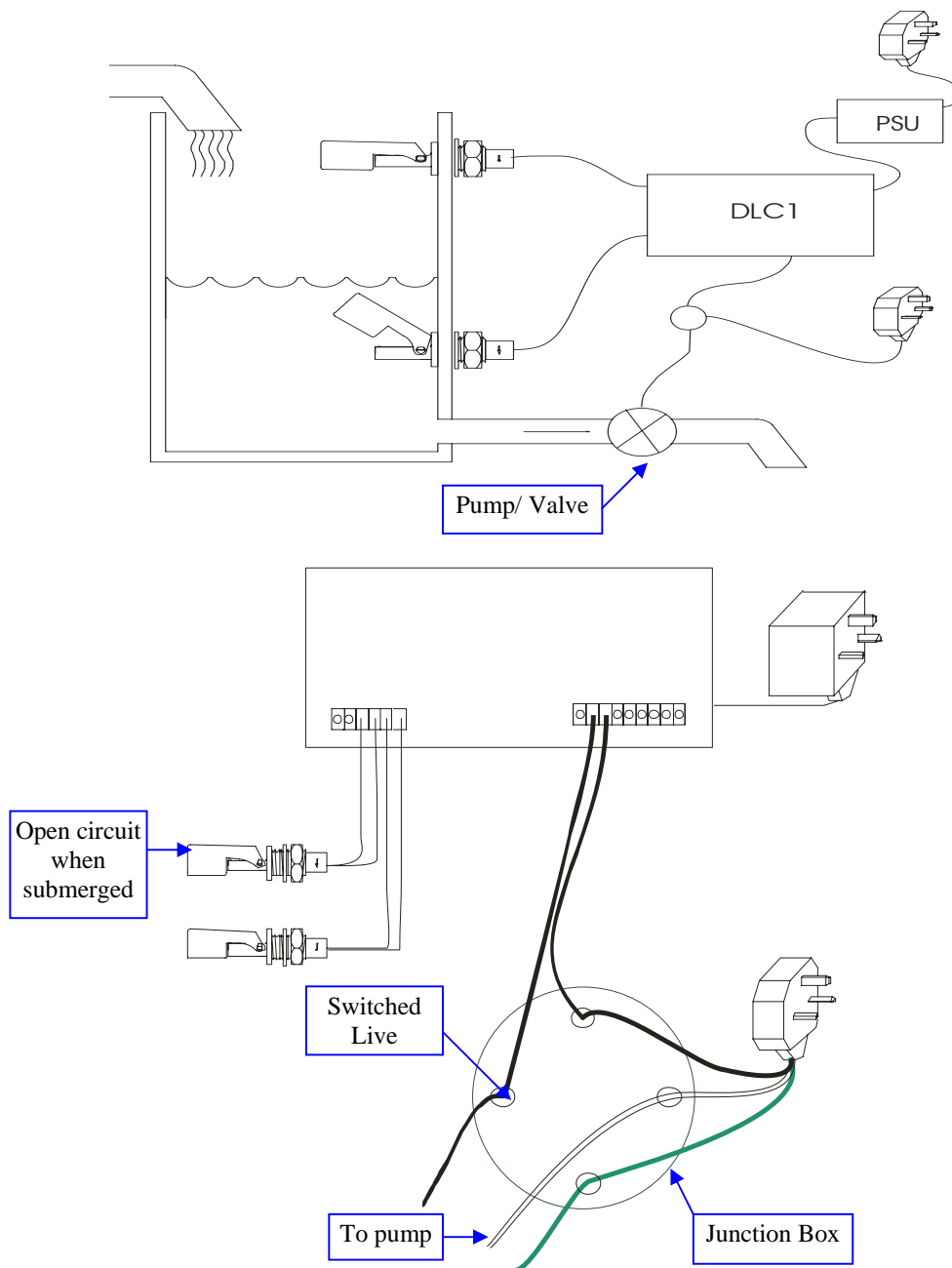

The DEETER Group[®]

This Diagram shows the 'Dual Level Controller 1' controlling a pump which fills a reservoir tank.

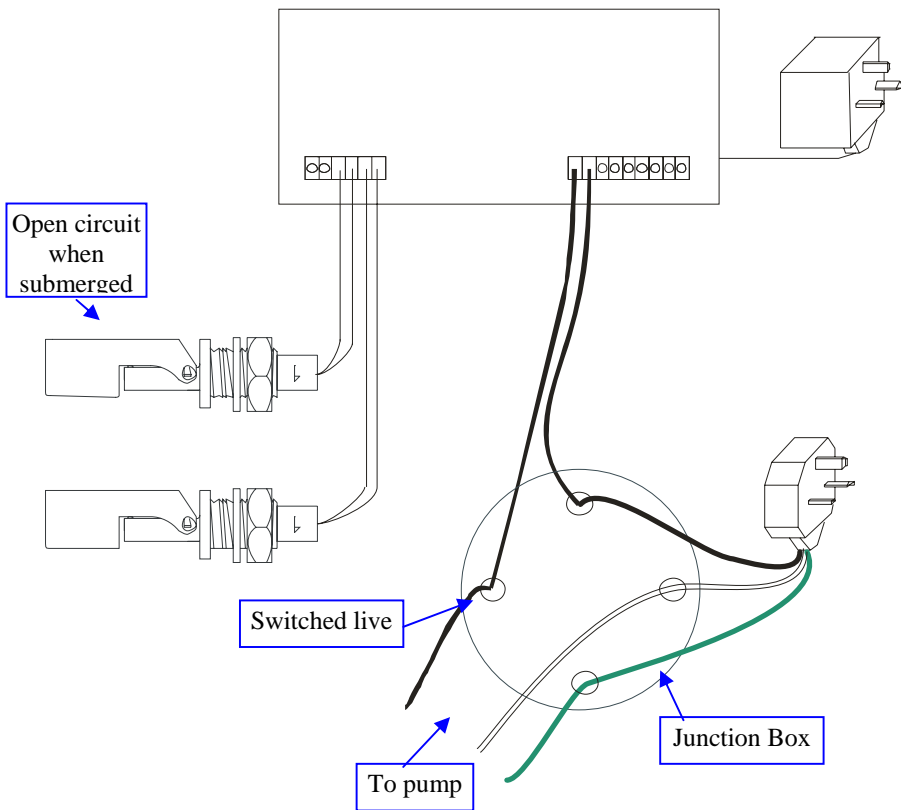
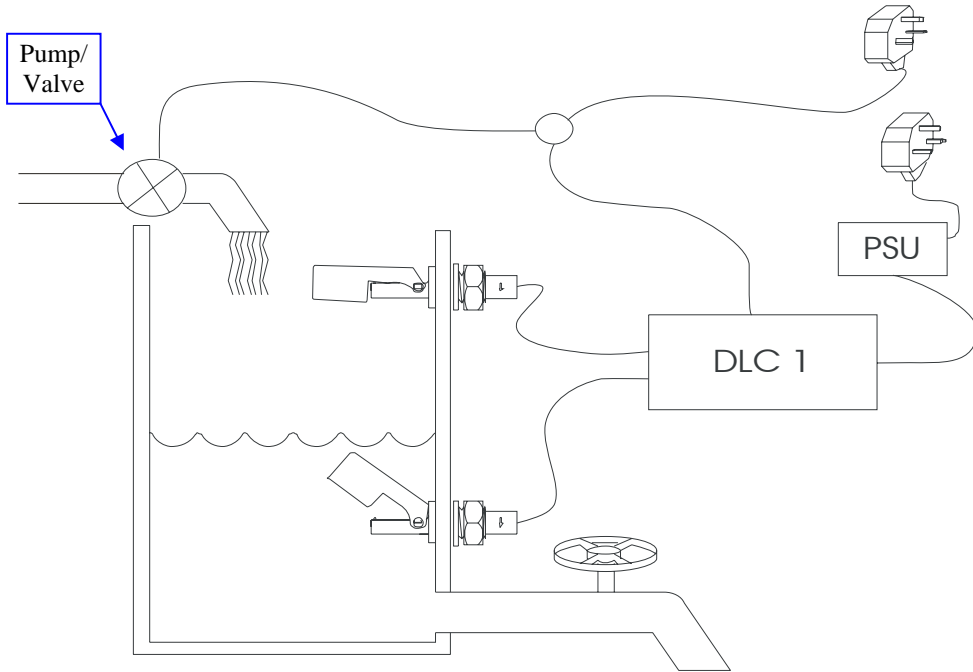

The DEETER Group[®]

This Diagram shows the 'Dual Level Controller 1' controlling a pump which fills a reservoir tank and has the ability to stop the pump should the water supply fail. Use a DLC2 to add an alarm for when the water supply fails.

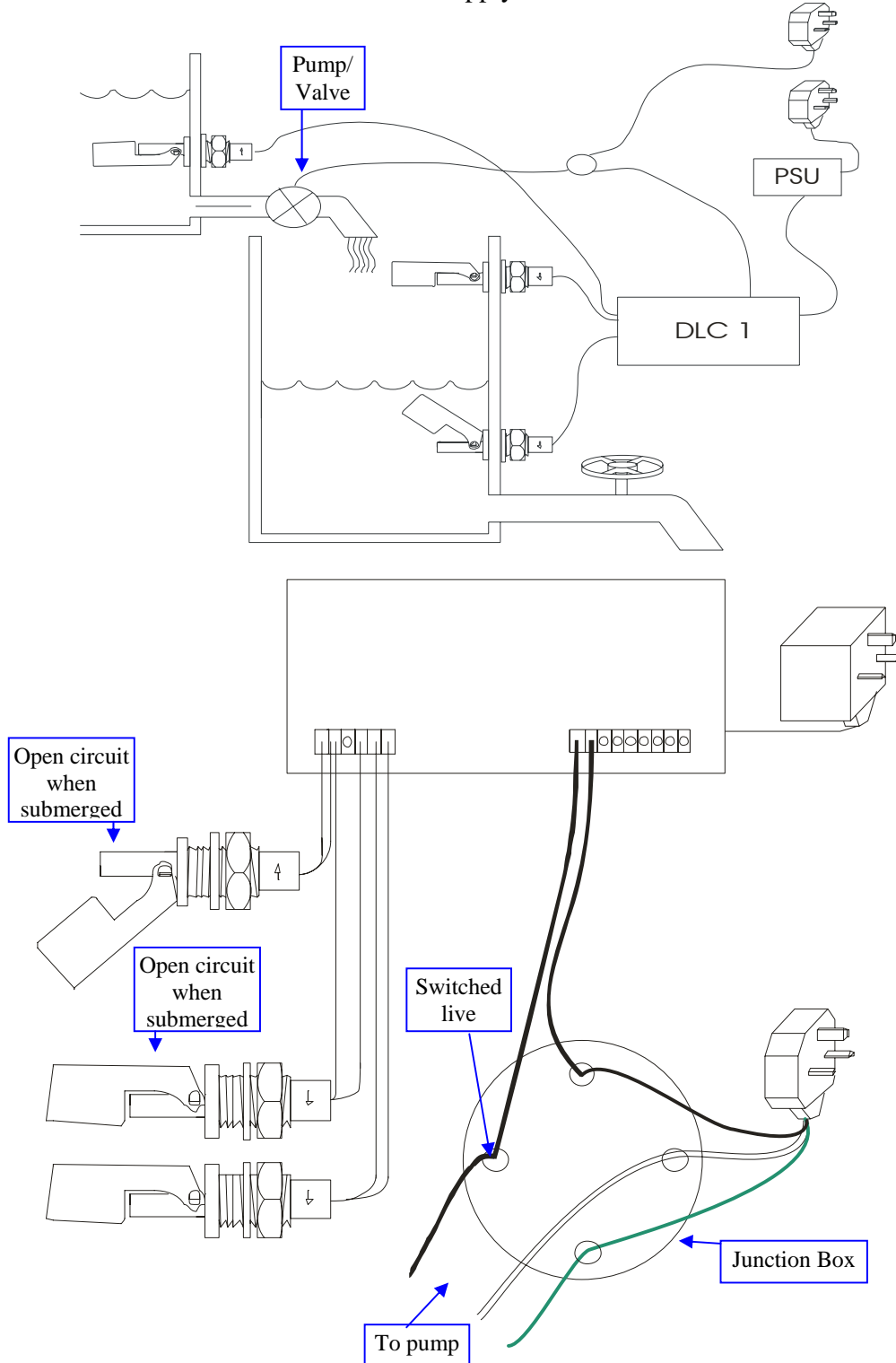

The DEETER Group[®]

This Diagram shows how a 'Dual Level Controller 2' can manage the liquid level by pumping out a constantly filling tank and raise an alarm should the tank over fill.

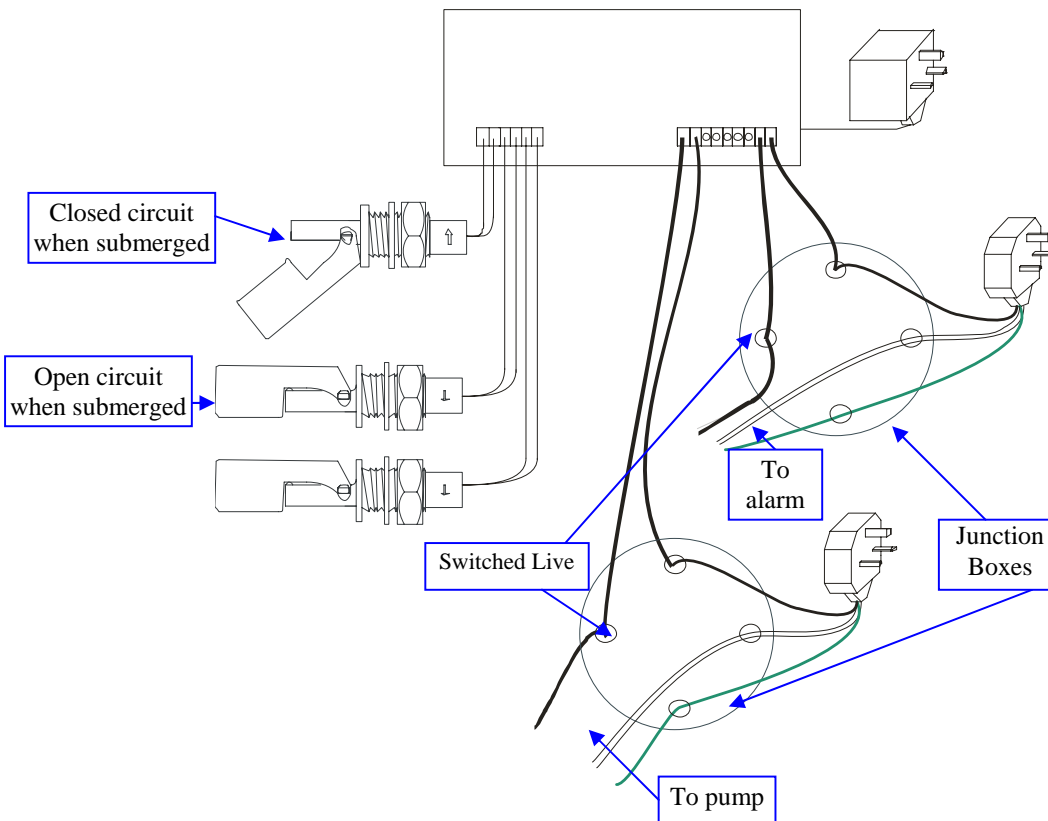
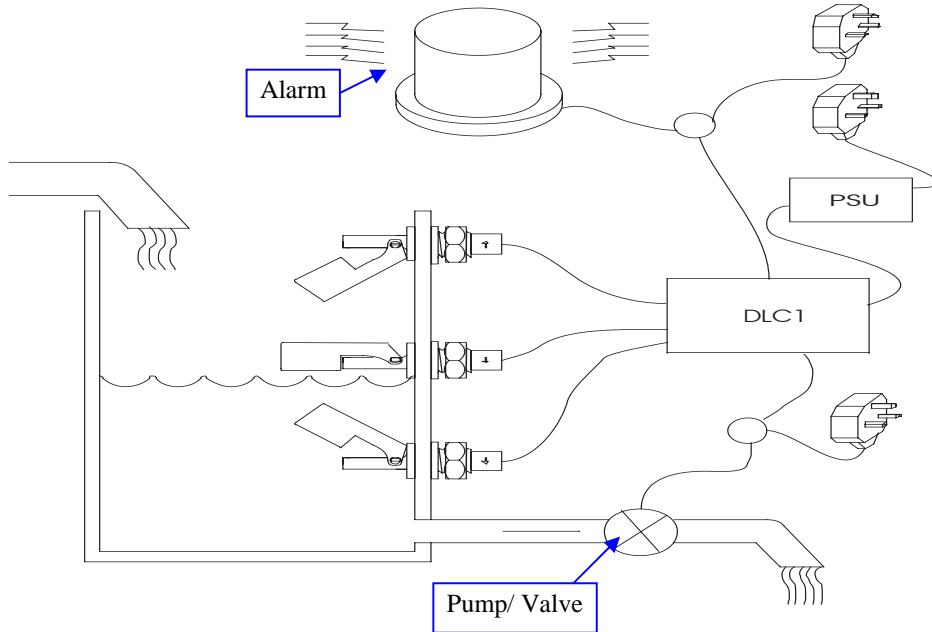

The DEETER Group[®]

This diagram shows how a 'Dual Level Controller 1' can control the liquid level using a single float switch, maintaining the liquid level at that single point.

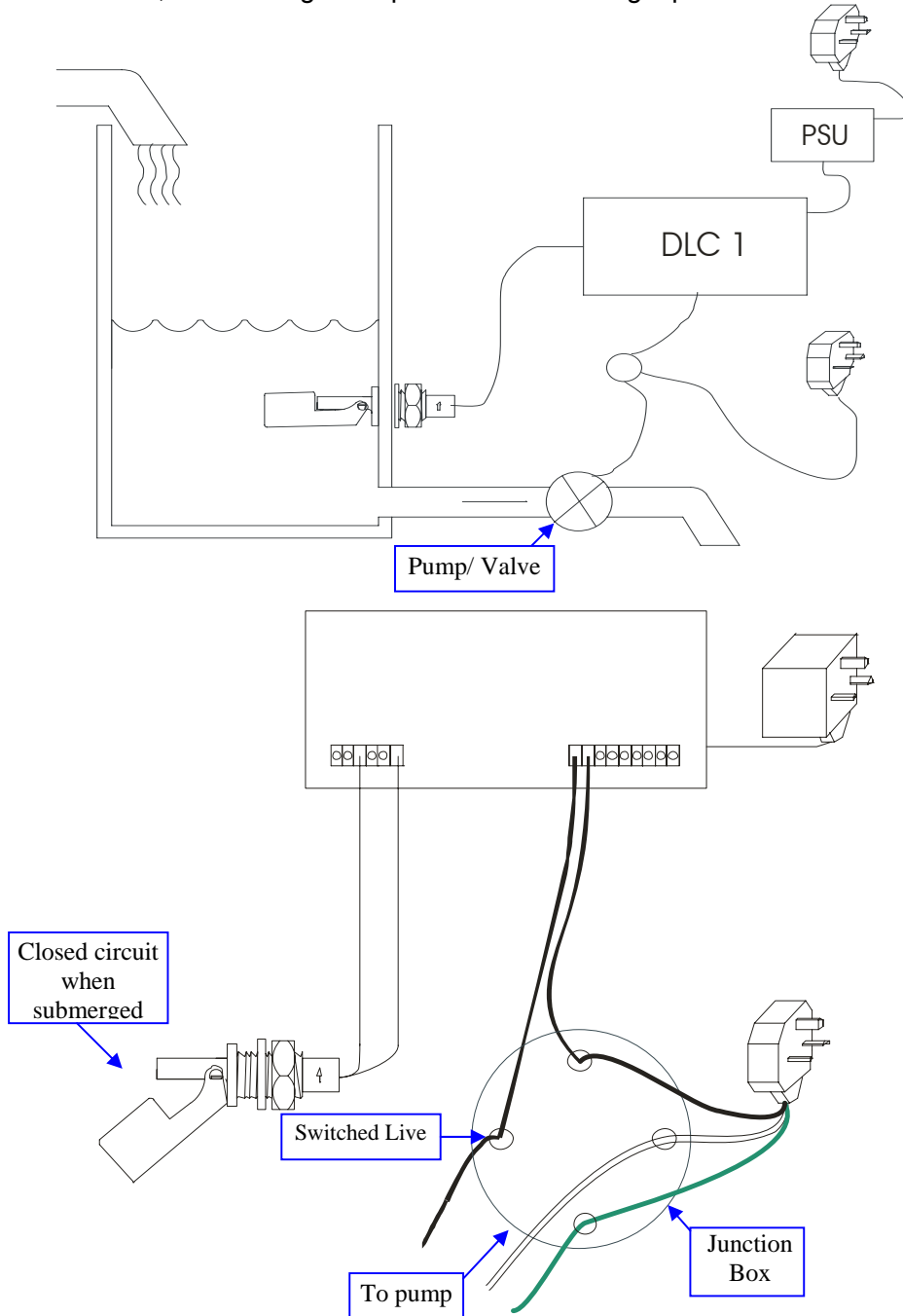

NB/ The above diagram is not desirable as continuously switching the pump on and off can cause damage to the pump.

In some applications it is necessary to mount a horizontal switch upside down to obtain normally closed contacts. Please contact Deeter for the alternative wiring diagrams if you have existing switches which do not match these diagrams.

The DEETER Group®

Safety Warnings



- **Disconnect the power supply from the pump and the controller before removing the control unit lid.**
- **Do not attempt to repair this product yourself; contact the Deeter Group for product servicing or repairs.**
- **Do not immerse the controller in water.**
- **Do not touch any electronic circuit should it become exposed.**
- **When disposing of this product, do so in accordance with your local waste disposal regulations.**

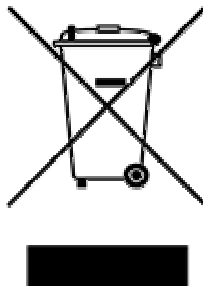

Deeter Group

If any parts are missing or damaged, please contact the Deeter Group at:

466 Commerce Street
Tallmadge
Ohio
44278

Tel: 001 330 630 3510

Fax: 001 330 630 3512

Sales@deeterelectronicsinc.com