

LVCS HE

Liquid Vertical Continuous Sensor

Hall Effect

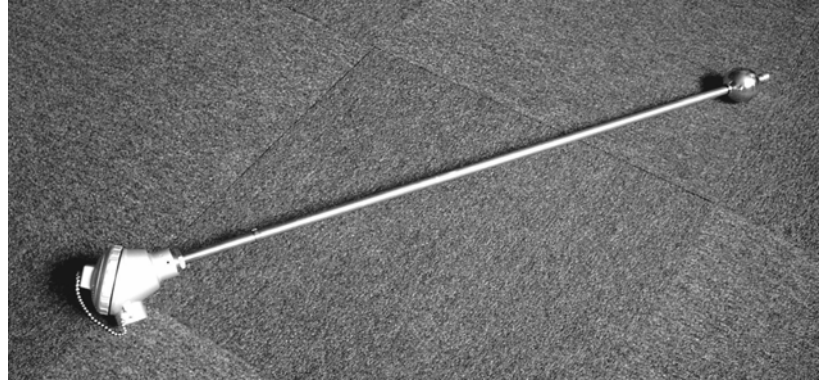
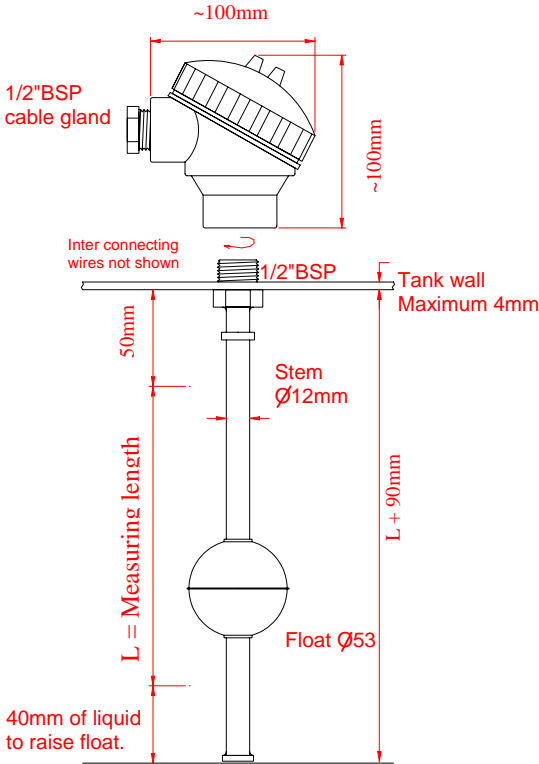

The LVCS HE is a liquid level sensor with a loop-powered 4-20mA output.

The LVCS HE has one moving part; a stainless steel float, which passes over sensors in a stainless steel stem with a sensing resolution of 15mm. It is designed to fit into a 21mm hole in the top of a tank, secured by an aluminium head. The standard head has a 1/2 inch BSP thread, for other threads or for fitting to pressured tanks, please call the sales office.

All fittings inside the tank are made from stainless steel 316L and are welded to make a tough and durable sensor. The LVCS is therefore ideally suited for use in food and petrochemical applications, and for use in harsh environments.

Custom lengths can be made to order – call our sales office to discuss your requirements. We will consider custom lengths, process connections and other resolutions.

The LVCS HE is an economical alternative to the Deeter standard LVCS and is suited to longer lengths. Other differences include:

- LVCS HE 5: Measured length L = 1250mm
- LVCS HE 6: Measured length L = 1500mm
- LVCS HE 7: Measured length L = 1750mm
- LVCS HE 8: Measured length L = 2000mm

Note: The overall length is 90mm longer than the measuring length. Please check you have enough tank depth to accommodate.

	Standard LVCS	LVCS HE
Resolution	5mm	15mm
Power supply	Separate Inputs	Loop Powered
Temperature range	-20C to +120C	-20C to +45C
Voltage output options	Yes	No
IP Rating	IP67	IP67

(Further details about the standard LVCS can be found on the website (www.deeter.co.uk) and by downloading a data sheet)

Specifications

Current Loop Supply Voltage	10VDC* – 30VDC	Maximum Current Loop Load Resistance	50ohms – 1kohms [#]
Current Loop Output	4-20mA	Temperature Range	-20 °C to 45 °C
Sensing Resolution	15mm	Connection Type	2-way screw terminal
Operating Pressure	450 PSI 31 Bar	Float Specific Gravity	0.65

* The minimum supply voltage is given by the formula: $V_{supply(min)} = (R_{load} \times 20mA) + 9V$, where R_{load} includes wiring resistance.

[#] Maximum load resistance (including wiring resistance) is given by the formula: $R_{load(max)} = (V_{supply} - 9V)/20mA$

LVCS HE – [] []

- 5 – 1250mm sensing range
- 6 – 1500mm sensing range
- 7 – 1750mm sensing range
- 8 – 2000mm sensing range
- Custom lengths available

DEETER Electronics Inc

66 Commerce Street, Tallmadge, OHIO 44278
 Tel: 001 330 630 3510 - Fax: 001 330 630 3512
 Email: sales@deeterelectronicinc.com
 Website www.deeterelectronicinc.com

Distributed by: